

Method Abstract

Summary: A known amount of soil sample is extracted with the appropriate solution, and the extract is then analyzed for orthophosphate. Orthophosphate reacts with molybdenum(VI) and antimony(III) in an acidic solution to form an antimony-phosphomolybdate complex. Ascorbic acid subsequently reduces this complex to form a blue color, and the absorbance is measured at 880 nm.

Interferences: Dialysis prior to color development removes most interferences. The presence of less than 50 mg/L of ferric iron, 10 mg/L of copper, or 10 mg/L of silica in the final extract does not interfere with the analysis.

Performance Specifications:

Range	1–100 mg/L phosphorus
Throughput	24 samples/hour
Precision at 1 mg/L	<5% RSD
10 mg/L	<3% RSD
50 mg/L	<2% RSD
Method Detection Limit (MDL)	0.1 mg/L

Chemicals:

Ammonium molybdate tetrahydrate, $(\text{NH}_4)_6\text{Mo}_7\text{O}_{24}\cdot 4\text{H}_2\text{O}$	Hydrochloric acid, concentrated, HCl
Antimony potassium tartrate hemihydrate, $\text{K}(\text{SbO})\text{C}_4\text{H}_4\text{O}_6\cdot \frac{1}{2}\text{H}_2\text{O}$	Mercuric chloride, HgCl_2
Ascorbic acid, $\text{C}_6\text{H}_8\text{O}_6$	Sodium chloride, NaCl
DOWFAX® 2A1	Sulfuric acid, concentrated, H_2SO_4

Basic Flow Diagram:

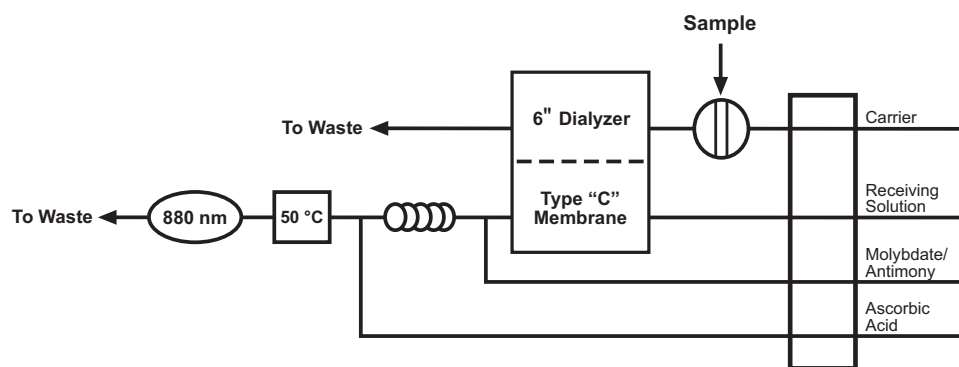

Selected References:

Phosphorus, All Forms. *Methods for Chemical Analysis of Water and Wastewater*; EPA-600/4-79-020; U.S. Environmental Protection Agency, Office of Research and Development, Environmental Monitoring and Support Laboratory: Cincinnati, OH, 1984; Method 365.1.

Standard Methods for the Examination of Water and Wastewater, 20th ed.; American Public Health Association: Washington, D.C., 1998.

DOWFAX is a registered trademark of Dow Chemical, Inc.