

**Summary:** Hexavalent chromium reacts with diphenylcarbazide in an acidic solution to form a red-violet colored complex. The absorbance of the chromium-diphenylcarbazide product is measured at 540 nm.

**Interferences:** Hexavalent molybdenum and mercury salts interfere in concentrations greater than 200 mg/L. Vanadium interferes in amounts greater than 10 times the concentration of chromium. Remove interfering amounts of molybdenum, vanadium, iron, and copper by extracting metal cupferrates into chloroform. Eliminate interference from permanganate by reduction with azide.

**Performance Specifications:**

Range:	0.10–10 mg/L
Throughput:	72 samples/hour
Precision:	
0.50 mg/L	<2% RSD
2.0 mg/L	<1% RSD
Method Detection Limit (MDL):	0.004 mg/L

<b>Chemicals:</b>	Brij®-35, 30% w/v (OI Analytical Part #A21-0110-33)	Kleenflow™ Basic (OI Analytical Part #A001252)
	1,5-Diphenylcarbazide, C <sub>13</sub> H <sub>14</sub> N <sub>4</sub> O	Potassium Dichromate, K <sub>2</sub> Cr <sub>2</sub> O <sub>7</sub>
	Isopropanol, 99%, C <sub>3</sub> H <sub>8</sub> O	Sulfuric Acid, concentrated, H <sub>2</sub> SO <sub>4</sub>

**Basic Flow Diagram:**

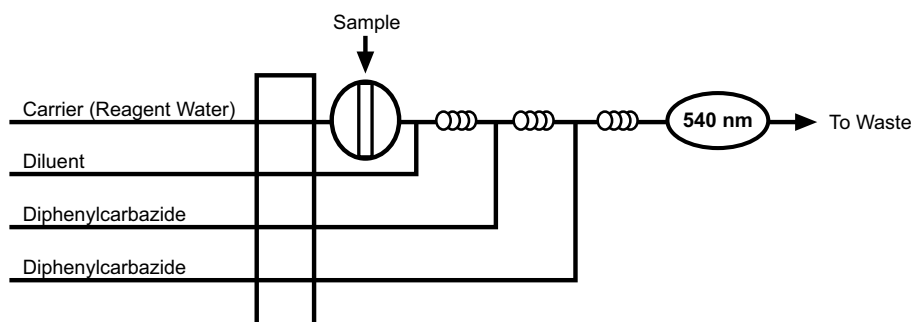

**Selected References:** *Methods for Chemical Analysis of Water and Wastewater*; EPA-600/4-79-020; U.S. Environmental Protection Agency, Office of Research and Development, Environmental Monitoring and Support Laboratory: Cincinnati, OH, 1984; Method 7196A.

*Standard Methods for the Examination of Water and Wastewater*, 20th ed.; American Public Health Association: Washington, D.C., 1998.

Brij is a registered trademark of ICI Americas.  
Kleenflow is a trademark of Ricca Chemicals.